

CRYOPORT ELITE™ 56L ULTRA COLD SHIPPER

PLEASE FOLLOW LOCAL RULES OF SAFE HANDLING AND DISPOSING OF DRY ICE

STEP 1

Wear the appropriate personal protective equipment (PPE) for handling extreme cold temperatures for the unloading of the payload and dry ice.



STEP 2

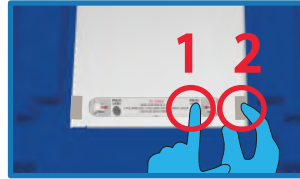

Open the document enclosure lid by pressing down on the lid while simultaneously pressing in each latch on the side one at a time, and then lifting the lid up.

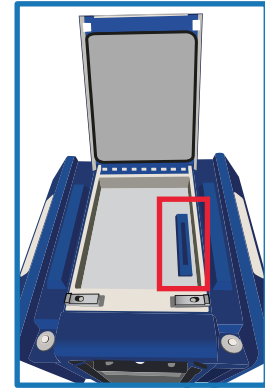

Once document enclosure lid is open, remove blue lid hinge stopper.

NOTE: The Advanced Therapy Shipper™ will come with a blue lid hinge stopper. The General Purpose Shipper will come with a gray lid hinge stopper.

STEP 3



Prior to removal of serialized zip tie, record serialized number onto all pertinent documentation. Remove serialized zip tie with wire cutters.

STEP 4

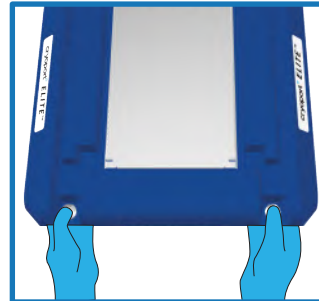

Open the shipper by simultaneously pressing the two buttons on the front of the lid. This will release the lid and provide access to the internal payload space by lifting upward to open the lid.

STEP 5

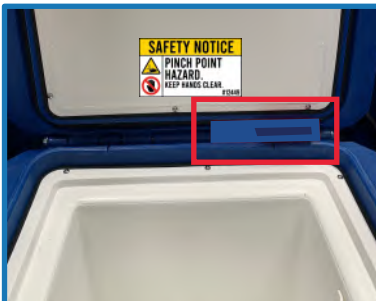

Once lid is open, utilize lid hinge stopper to keep lid propped open and prevent any personal injury. The stopper should be placed by sliding inward from either side position of the hinge (located between the lid and the base). Lid hinge stopper is located in the document enclosure.

NOTE: The Advanced Therapy Shipper™ will come with a blue lid hinge stopper. The General Purpose Shipper will come with a gray lid hinge stopper.

STEP 6



Prior to removal of serialized zip ties, record serialized number onto all pertinent documentation. Remove serialized zip tie with wire cutters.

CRYOPORT ELITE™ 56L ULTRA COLD SHIPPER

PLEASE FOLLOW LOCAL RULES OF SAFE HANDLING AND DISPOSING OF DRY ICE

STEP 7

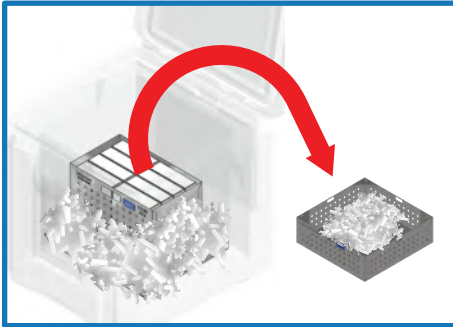

Remove Top Dry Ice Compartment with dry ice remaining inside. Properly dispose the dry ice from the Top Dry Ice Compartment.

STEP 8

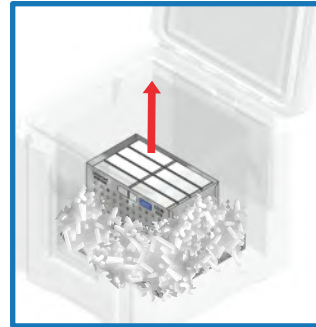

Remove the payload from the Payload Carrier.

STEP 9

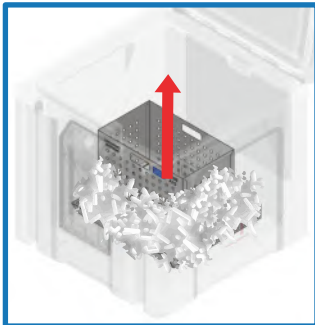

Remove and properly dispose of any remaining dry ice around the Payload Carrier.

STEP 10

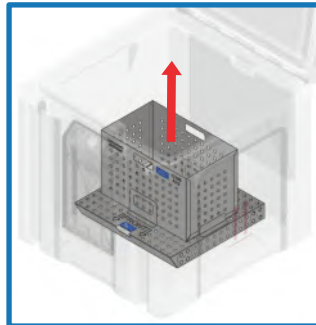

Remove the Payload Carrier to gain access to the Bottom Dry Ice Compartment.

STEP 11

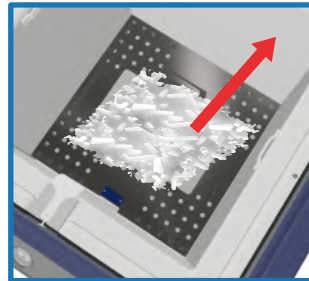

Remove and dispose any leftover dry ice in the Bottom Dry Ice Compartment.

STEP 12

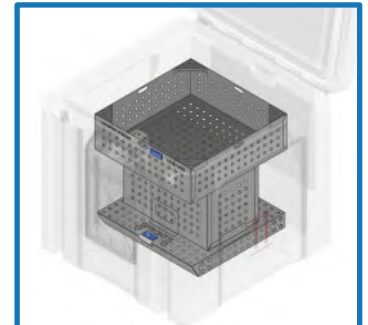

Make sure the Shipper is empty of all dry ice and confirm the Payload Holding System is inside the shipper prior to the return to Cryoport.

STEP 13



When closing the shipper lid, first remove the lid hinge stopper, and place the stopper back into document enclosure. Close the shipper by pressing down on the left corner first until you hear an audible 'click'. Then press down on the right side until you hear another 'click' to close the shipper's lid. The audible 'clicks' will ensure the both latches are engaged.

STEP 14

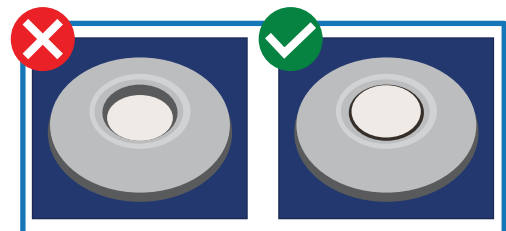

The center buttons will eject and appear flush when the latches are successfully engaged.

NOTE: As stated in the prior step, user must hear an audible 'click' from both sides in order for the center buttons to eject and the latches to successfully engage.

CRYOPORT ELITE™ 56L ULTRA COLD SHIPPER

PLEASE FOLLOW LOCAL RULES OF SAFE HANDLING AND DISPOSING OF DRY ICE

STEP 15

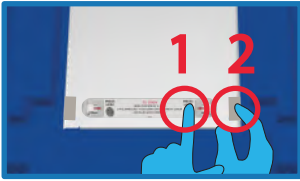

To obtain the return shipment documentation, open the document enclosure lid by pressing down on the lid while simultaneously pressing in each latch on the side one at a time, and then lifting the lid up.



The document enclosure will contain a pouch with the necessary documents and applicable labels.

STEP 16

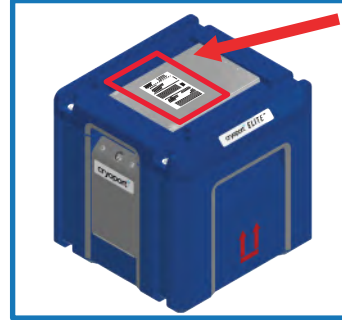

Contact the courier to provide the weight of the dry ice contained in the shipper for generating the return Air Waybill.

Print the Air Waybill provided by the courier and insert into the shipping envelope on the top of the shipper.

STEP 17

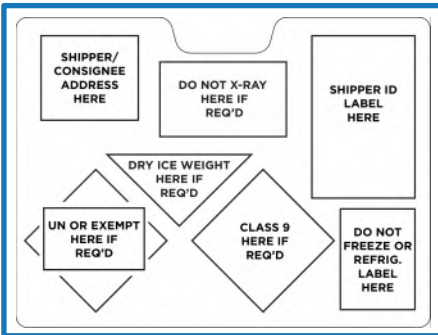

Remove any courier labels or stickers currently on the Cryoport Elite™ Shipper.

Remove the labels from the shipping envelope on top of the shipper.

Place the "Empty" labels on the UN3373, UN1845, and Class 9 DG designated locations on the back of the shipper.



NOTE: Also verify that the lid hinge stopper is placed back into the document enclosure. If shipper is returned without stopper, there will be a replacement charge.